

Operating Manual

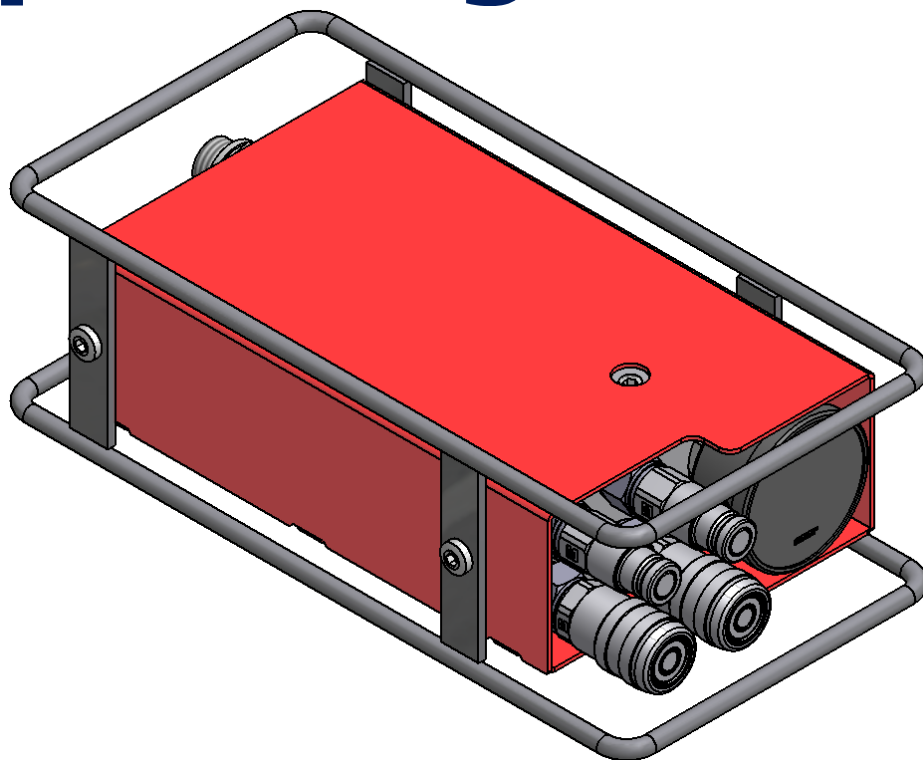

HBU630 Hydraulic Booster Unit

From serial number 12407

Revised November 2017



HYCON A/S
Juelstrupparken 11
DK-9530 Støvring
Denmark

Tel: +45 9647 5200
Fax: +45 9647 5201
Mail hycon@hycon.dk
www.hycon.dk

Prior to Operation

We thank you for choosing a HYCON booster unit.

We recommend you to study this operating manual carefully and pay special attention to the chapter about **safety precautions, filtration and couplings**

We hope you will be satisfied with your new HYCON booster unit.

Best regards
HYCON A/S

Contents

Prior to Operation	2
High Pressure Hydraulic Systems	3
Safety Precautions	3
How does it work	4
How to connect	4
Technical Data	5
Filtration	6
Couplings	7
Service and Maintenance	8
Oil Types	8
Warranty Terms	8
Spare part list	9

High Pressure Hydraulic Systems

High pressure is generally defined as systems that can generate a pressure up to 800 bars. The HYCON booster can generate a pressure up to 630 bars.

The other HYCON products operate on a pressure up to 160 bar and our extension hoses are approved up to 350 bars pressure. There must always be a safety factor. High pressure systems use special couplings and hoses that must be approved for the pressure that any customer using a HYCON booster will be using.

Safety Precautions

- Working with high pressure hydraulics can be very dangerous. Make sure that you have read the operation manual for the powerpack, HBU630 booster and for the high pressure hydraulic tool.
- A fine jet of oil at pressure can penetrate the skin. It is therefore important never to use your fingers to check for oil leaks and never to hold your face close to suspected leaks – use a piece of cardboard instead. If oil has penetrated the skin, you should get medical treatment immediately.
- Always use approved hoses - contact your dealer, if necessary. Mount the hoses correctly. See the chapter about "Connection".
- High oil temperature may result in the booster unit getting warmer than usual and the operator risks getting burnt on it.
- To avoid all personal injury and damage to material, all repair, maintenance and service work must be carried out by authorized or properly trained persons only.

IMPORTANT

- Always use hoses, couplings and spares as such recommend by HYCON A/S.
- Repairs may only be carried out by experienced personnel.
- Make sure that all couplings are cleaned before connection.
- Always disconnect the hydraulic supply unit before connecting or disconnecting the tool from the booster unit. If this is not done, there is a risk of damage to the quick release couplings or the hydraulic system.

How does it work

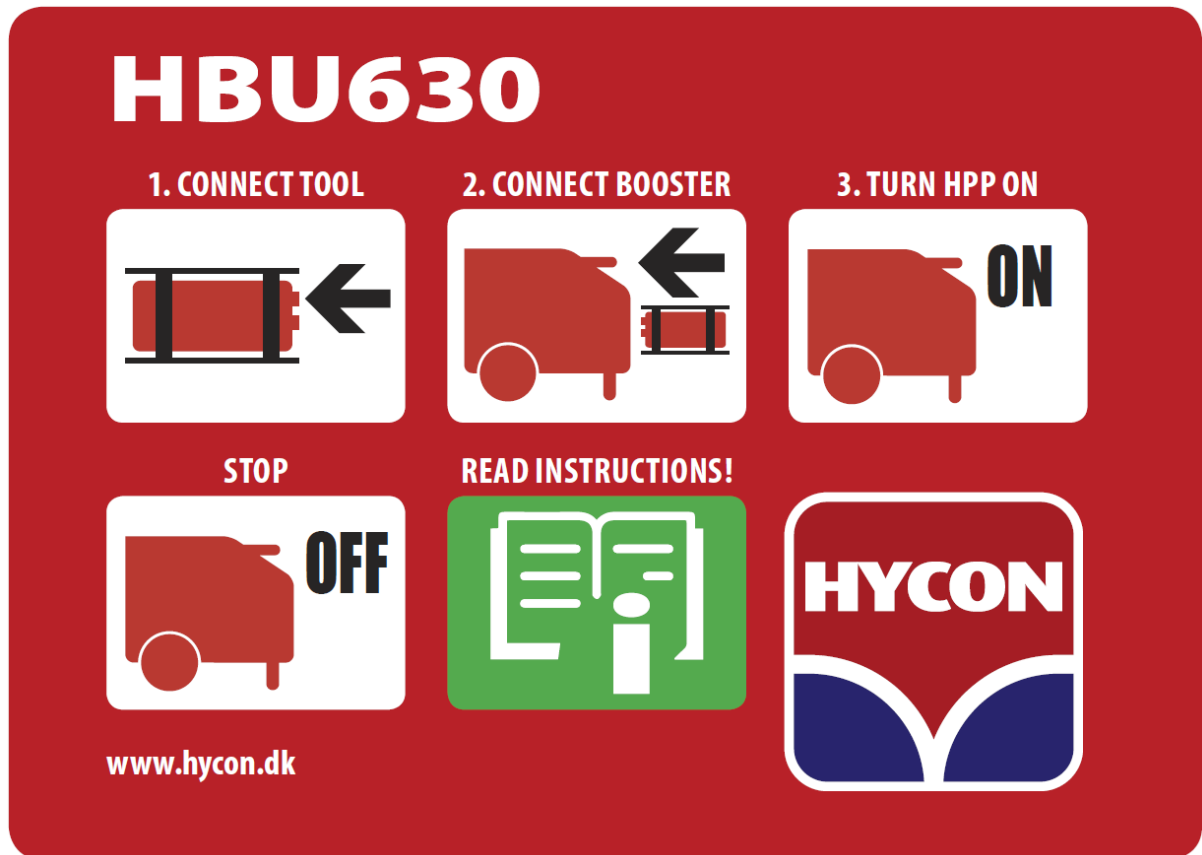

How to connect

To ensure easy workflow the following connection procedure should be followed.

Start

1. Connect the high pressure tool to the HBU630 booster unit.
2. Connect the HBU630 booster unit, to the power pack.
3. Start the power pack and activate the output.
4. The booster should now start to click and the high pressure tool should now be ready to be used.

Stop

1. Deactivate the output on the power pack to stop the booster unit.

If the procedure is not followed and the HBU630 is started without the high pressure tool connected the booster will build up pressure and trying to connect a tool with pressure in the system can damage couplings.



WARNING! The following procedure should only be performed with the system disconnected from any power source. Trying this with the booster running can damage the booster and result in personal injury.

If there is a pressure build-up in the system, loosen the screw on top of the HBU630 marked with "Pressure Relief" this will depressurise the system. **Remember to tighten the screw again. Maximum 10 NM**

Technical Data

INLET CONNECTION

Oil flow (power source) Max. 20 l.p.m. / 5 g.p.m.

Pressure relief valve (power source) Max. 170 bar / 2500 psi

OUTPUT CONNECTION

Oil flow out Max. 5 l.p.m. / 1,3 g.p.m.

Pressure relief valve Standard setting is max 500 bar / 7300 psi

Maximum pressure is 630 bar / 9000 psi

Maximum pressure is set pr. Request.

OIL VOLUME

Make sure that the oil volume on the power source, is sufficient to fill the hydraulic tool that is being used.

FILTRATION

The power source must have a filtration of maximum 10 micron

MIN. COOLING

The power source must have a minimum cooling capacity of 2,7 kW

The maximum allowed oil temperature is 70°C / 158°F

DIMENSIONS

34 cm (L) x 17 cm (W) x 15 cm (H)
13-3/8" (L) x 6-5/8" (W) x 5-7/8" (H)

WEIGHT

14kg / 31 lbs

Filtration



Important! When using a Hycon HBU630 booster unit it is very important to ensure that the hydraulic circuit has a maximum 10-micron filter. Not ensuring this can cause breakdown and damaged parts.

Supplied with the HBU630 is a **10-micron** filter that fits into a HYCON Power pack.

Before using the HBU630, replace the filter in the power pack and insert the new 10-micron filter. When the filter is changed, start the power pack without any tools connected, and let it run for 5 minutes. After that turn off the power pack. This will ensure that all the oil in the system is filtrated.

After this, you are ready to use the HBU630 booster unit.

If the powerpack is used with other hydraulic tools, filter inspection rate should be increased.



Every time the HBU 630 is used a short filtration pre-run is recommended.

The HYCON 10 micron filter has HYCON part no. 9422417

If you are using another power source make sure that the filtration is 10-micron.

Couplings

The HBU630 has low-pressure supply quick release couplings that can be used with all HYCON Power Packs.



Important! The high pressure couplings used must be rated for the pressure value on the machine tag. Failing to use suitable couplings can in worst case result in personal injury and damage.

The HBU630 is delivered without high-pressure couplings, these should be bought by the customer and be designed to fit the high pressure tool used with the HBU630.

The HBU630 valveblok has Female 1/4"-BSPP Threads.

The high-pressure couplings should be selected and installed by a hydraulic specialist with high pressure experience. The high pressure ports is marked with a "P" where the ports with low pressure tank connection is marked with "T". See image below.

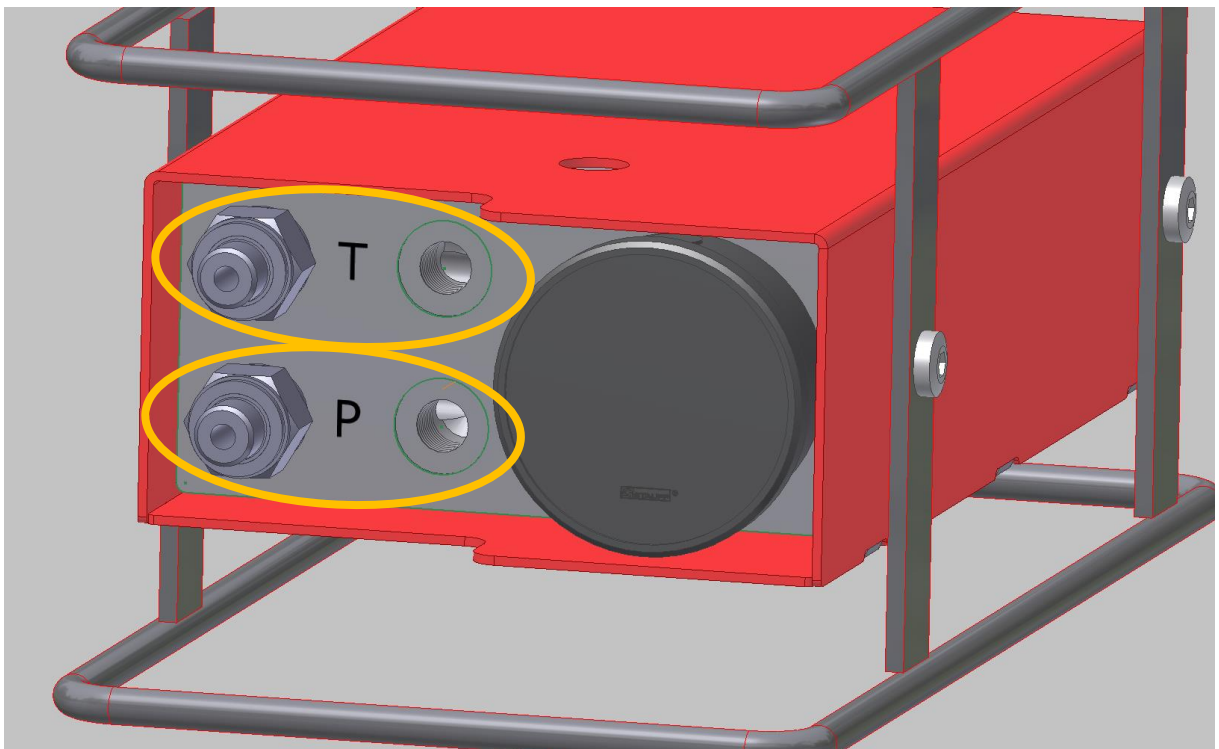

Service and Maintenance

Service/Maintenance	Daily	Weekly	Yearly
Check couplings and clean carefully	X		
Check hoses	X		
Check filter		X	

Oil Types

HYCON tools use standard hydraulic oil, i.e. all types of mineral oil and biodegradable oil, which comply with the following values:

Recommended viscosity	20-40 cSt
Permitted viscosity	15-1000 cSt
Viscosity index	Min. 100
Temperature area	-20° C to +70° C -4° F to + 158° F

If using biodegradable oil, we recommend the use of oil based on rape. Other types of oil can be aggressive towards the seals. If you are in doubt, please ask your dealer.

Warranty Terms

We grant 12 months warranty from the first date of operation – however, not more than 18 months from the date of delivery.

The warranty applies to faults that can be related to construction and production errors.

Faults caused by incorrect operation, incorrect handling, lack of maintenance or the like, will not be accepted as warranty.

The warranty covers the parts necessary for repair and the suggested average time needed for repair.

For further warranty details, please contact your local dealer.

EC-Declaration of Conformity

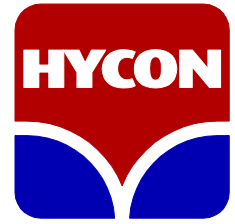

HYCON A/S
Juelstrupparken 11
DK-9530 Støvring
Denmark

Tel: +45 9647 5200
Fax: +45 9647 5201
Mail hycon@hycon.dk
www.hycon.dk

We hereby confirm that **HBU630**

From Serial No.

12407

are manufactured in conformity with EC-directive 2006/42/EC.

HYCON A/S
Juelstrupparken 11
DK-9530 Støvring
Denmark

A handwritten signature in blue ink, appearing to read "Martin Møller".

Martin Møller
Managing Director
28.05.2018