



# TP03 HYDRAULIC TRASH PUMP

## ⚠ WARNING

SERIOUS INJURY OR DEATH  
COULD RESULT FROM IM-  
PROPER REPAIR OR SERVICE  
OF THIS TOOL.

REPAIRS AND/OR SERVICE  
TO THIS TOOL MUST ONLY  
BE DONE BY AN AUTHORIZED  
AND CERTIFIED DEALER.

## ⚠ WARNING

To avoid serious injury or death

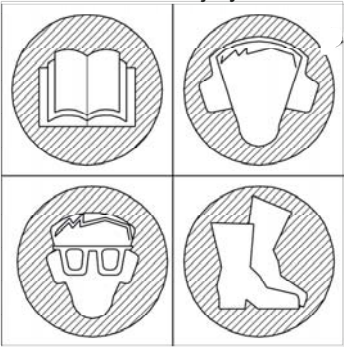

## SAFETY, OPERATION AND MAINTENANCE USER'S MANUAL



© 2006 The Stanley Works  
OPS/MAINT USA  
Printed in U.S.A.  
58555 4/2006 ver 3

Stanley Hydraulic Tools  
3810 SE Naef Road  
Milwaukie OR 97267-5698  
503-659-5660  
FAX 503-652-1780  
[www.stanley-hydraulic-tools.com](http://www.stanley-hydraulic-tools.com)

---

---

---

# TABLE OF CONTENTS

---

CERTIFICATE OF CONFORMITY .....	4
SAFETY SYMBOLS.....	5
SAFETY PRECAUTIONS.....	6
TOOL STICKERS & TAGS .....	8
HYDRAULIC HOSE REQUIREMENTS.....	9
HTMA REQUIREMENTS.....	10
OPERATION.....	11
PREOPERATION PROCEDURES .....	11
CHECK POWER SOURCE .....	11
CONNECT HOSES.....	11
PUMP OPERATION.....	11
COLD WEATHER OPERATION .....	12
EQUIPMENT PROTECTION & CARE.....	13
TROUBLESHOOTING.....	14
SPECIFICATIONS .....	15
ACCESSORIES.....	15
TP03 PARTS ILLUSTRATION .....	16
TP03 PARTS LIST.....	17
WARRANTY .....	18

**SERVICING THE STANLEY HYDRAULIC Trash Pump.** This manual contains safety, operation, and routine maintenance instructions. Stanley Hydraulic Tools recommends that servicing of hydraulic tools, other than routine maintenance, be performed by an authorized and certified dealer. Please read the following warning.

**⚠ WARNING**

**SERIOUS INJURY OR DEATH COULD RESULT FROM THE IMPROPER REPAIR OR SERVICE OF THIS TOOL.**

**REPAIRS AND / OR SERVICE TO THIS TOOL MUST ONLY BE DONE BY AN AUTHORIZED AND CERTIFIED DEALER.**

For the nearest authorized and certified dealer, call Stanley Hydraulic Tools at the number listed on the back of this manual and ask for a Customer Service Representative.

# CERTIFICATE OF CONFORMITY

CERTIFICATE OF CONFORMITY  
 ÜBEREINSTIMMUNGS-ZERTIFIKAT  
 CERTIFICAT DE CONFORMITE CEE  
 CERTIFICADO DE CONFORMIDAD  
 CERTIFICATO DI CONFORMITA



Hydraulic Tools

I, the undersigned:  
 Ich, der Unterzeichnende:  
 Je soussigné:  
 El abajo firmante:  
 lo sottoscritto:

**Mellits, Kirk E.**

Surname and First names/Familienname und Vornamen/Nom et prénom/Nombre y apellido/Cognome e nome

hereby certify that the construction plant or equipment specified hereunder:  
**bestätige hiermit, daß das im folgenden genannten Werk oder Gerät:**  
**certifies par ceci que l' usine ou l' équipement de construction indiqué cidessous:**  
**por el presente certifico que la fabrica o el equipo especificado a continuacion:**  
**certifico che l'impianto o l'attrezzatura sotto specificata:**

- Category: Trash Pump, Hydraulic  
 Kategorie:  
 Catégorie:  
 Categoria:  
 Categoría:
- Make/Ausführung/Marque/Marca/Marca **Stanley**
- Type/Typ/Type/Tipo/Tipo: TP0300301, TP0300303
- Serial number of equipment:  
 Seriennummer des Geräts:  
 Numéro de série de l'équipement:  
 Numero de serie del equipo:  
 Matricola dell'attrezzatura:

**All**

- Year of manufacture/Baujahr/année de fabrication/Año de fabricacion/Anno di fabbricazione **2001**

**Has been manufactured in conformity with - EEC Type examination as shown.**  
**Wurde hergestellt in Übereinstimmung mit - EEC Typ-Prüfung nach.**  
**Est fabriqué conformément - au(x) type(s) examiné(s) comme indiqué dans le tableau ci-après.**  
**Ha sido fabricado de acuerdo con - tipo examen EEC como dice.**  
**E' stata costruita in conformità con - le norme CEE come illustrato.**

Examen CEE de type				
Directive Richtlinie Directives particulières Directriz Direttiva	No. Nr Numéro No n.	Date Datum Date Fecha Data	Approved body Prüfung durch Organisme agréé Aprobado Collaudato	Date of expiry Ablaufdatum Date d'expiration Fecha de caducidad Data di scadenza
EN EN ISO Machinery Directive	809 3744 98/37/EC	2001 2001 1998	Self Self Self	NA NA NA

- Special Provisions: None  
 Spezielle Bestimmungen:  
 Dispositions particulières:  
 Provisiones especiales:  
 Disposizioni speciali:

Done at/Ort/Fait à/Dado en/Fatto a Stanley Hydraulic Tools, Milwaukie, Oregon USA Date/Datum/le/Fecha/Data **2001**

Signature/Unterschrift/Signature/Firma/Firma *Kirk E. Mellits*

Position/Position/Fonction/Puesto/Posizione Engineering Manager

---

# SAFETY SYMBOLS

---

Safety symbols and signal words, as shown below, are used to emphasize all operator, maintenance and repair actions which, if not strictly followed, could result in a life-threatening situation, bodily injury or damage to equipment.



This is the safety alert symbol. It is used to alert you to potential personal injury hazards. Obey all safety messages that follow this symbol to avoid possible injury or death.



This safety alert and signal word indicate an imminently hazardous situation which, if not avoided, will result in death or serious injury.



This safety alert and signal word indicate a potentially hazardous situation which, if not avoided, could result in death or serious injury.



This safety alert and signal word indicate a potentially hazardous situation which, if not avoided, may result in minor or moderate injury.



This signal word indicates a potentially hazardous situation which, if not avoided, may result in property damage.



This signal word indicates a situation which, if not avoided, will result in damage to the equipment.



This signal word indicates a situation which, if not avoided, may result in damage to the equipment.

Always observe safety symbols. They are included for your safety and for the protection of the tool.

## LOCAL SAFETY REGULATIONS

Enter any local safety regulations here. Keep these instructions in an area accessible to the operator and maintenance personnel.

---

---

---

---

---

---

---

---

---

---

---

# SAFETY PRECAUTIONS

---

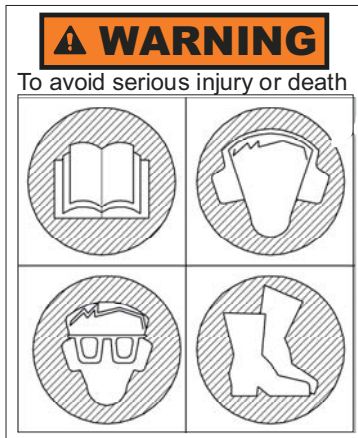

Tool operators and maintenance personnel must always comply with the safety precautions given in this manual and on the stickers and tags attached to the tool and hose.

These safety precautions are given for your safety. Review them carefully before operating the tool and before performing general maintenance or repairs.

Supervising personnel should develop additional precautions relating to the specific work area and local safety regulations. If so, place the added precautions in the space provided in this manual.

The models TP03 Hydraulic Trash Pump will provide safe and dependable service if operated in accordance with the instructions given in this manual. Read and understand this manual and any stickers and tags attached to the tool and hoses before operation. Failure to do so could result in personal injury or equipment damage.

- Operator must start in a work area without bystanders. The operator must be familiar with all prohibited work areas such as excessive slopes and dangerous terrain conditions.
- Establish a training program for all operators to ensure safe operations.
- Do not operate the tool unless thoroughly trained or under the supervision of an instructor.
- Always wear safety equipment such as goggles, head protection, and safety shoes at all times when operating the tool.
- Do not inspect or clean the tool while the hydraulic power source is connected. Accidental engagement of the tool can cause serious injury.
- Do not operate this tool without first reading the Operating Instructions.
- Do not install or remove this tool while the hydraulic power source is connected. Accidental engagement of the tool can cause serious injury.
- Never operate the tool near energized transmission lines. Know the location of buried or covered services before starting work.
- Do not wear loose fitting clothing when operating the tool. Loose fitting clothing can get entangled with the tool and cause serious injury.
- Supply hoses must have a minimum working pressure rating of 2500 psi/175 bar.
- Be sure all hose connections are tight.
- The hydraulic circuit control valve must be in the "OFF" position when coupling or uncoupling the tool. Wipe all couplers clean before connecting. Failure to do so may result in damage to the quick couplers and cause overheating. Use only lint-free cloths.
- Do not operate the tool at oil temperatures above 140° F/60° C. Operation at higher oil temperatures can cause operator discomfort and may cause damage to the tool.
- Do not operate a damaged, improperly adjusted, or incompletely assembled tool.

---

# SAFETY PRECAUTIONS

---

- To avoid personal injury or equipment damage, all tool repair, maintenance and service must only be performed by authorized and properly trained personnel.
- Do not exceed the rated limits of the tool or use the tool for applications beyond its design capacity.
- Always keep critical tool markings, such as labels and warning stickers legible.
- Always replace parts with replacement parts recommended by Stanley Hydraulic Tools.
- Check fastener tightness often and before each use daily.
- Do not put your hands or any other body part under the volute while the trash pump is running.
- Do not lift the trash pump by pulling on the hydraulic hoses. Use a suitable line fastened to the trash pump handle.
- Do not point water discharge toward bystanders.

# TOOL STICKERS & TAGS

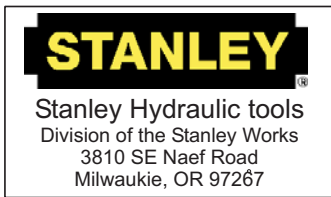

05152  
Stanley Logo Decal



28322  
CE Decal (CE Only)

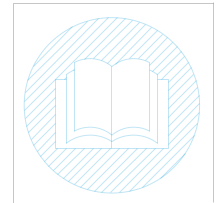

28788  
Manual Decal  
(CE Only)



03786  
GPM Decal



11207  
Circuit Type D Decal  
(CE Only)

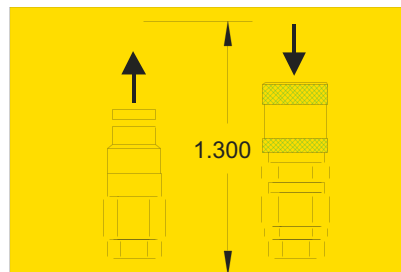

28786  
Coupler Decal

The safety tag (p/n 15875) at right is attached to the tool when shipped from the factory. Read and understand the safety instructions listed on this tag before removal. We suggest you retain this tag and attach it to the tool when not in use.

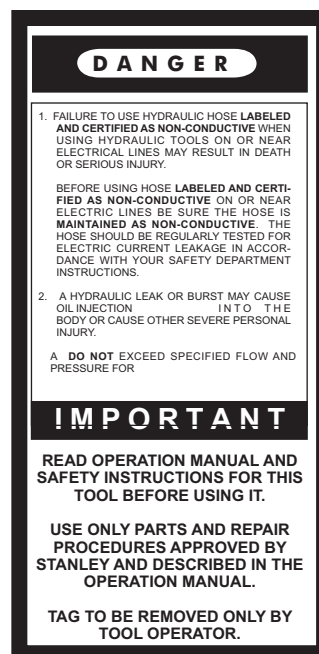

SAFETY TAG P/N 15875 (shown smaller than actual size)



# HYDRAULIC HOSE REQUIREMENTS

## HOSE TYPES

Hydraulic hose types authorized for use with Stanley Hydraulic Tools are as follows:

- 1 Certified non-conductive
- 2 Wire-braided (conductive)
- 3 Fabric-braided (not certified or labeled non-conductive)

Hose 1 listed above is the only hose authorized for use near electrical conductors.

Hoses 2 and 3 listed above are **conductive** and **must never** be used near electrical conductors.

## HOSE SAFETY TAGS

To help ensure your safety, the following DANGER tags are attached to all hose purchased from Stanley Hydraulic Tools. **DO NOT REMOVE THESE TAGS.**

If the information on a tag is illegible because of wear or damage, replace the tag immediately. A new tag may be obtained from your Stanley Distributor.

### THE TAG SHOWN BELOW IS ATTACHED TO “CERTIFIED NON-CONDUCTIVE” HOSE

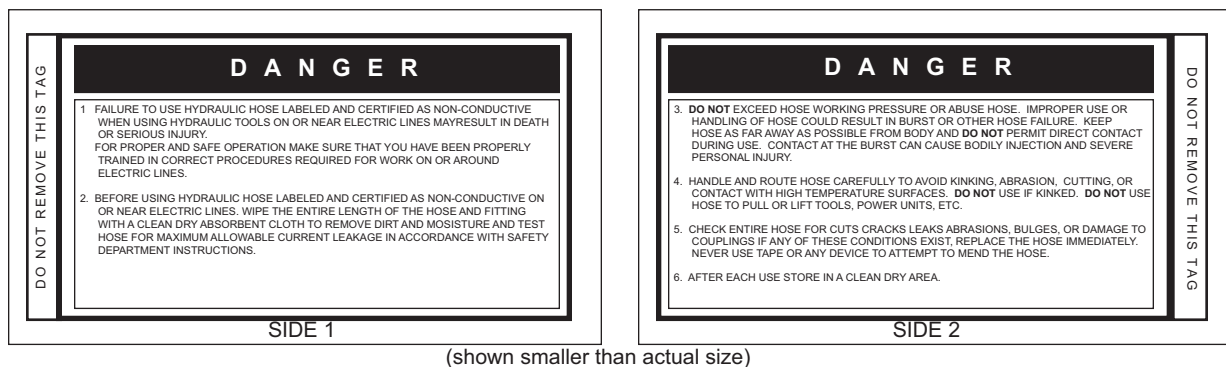

### THE TAG SHOWN BELOW IS ATTACHED TO “CONDUCTIVE” HOSE.

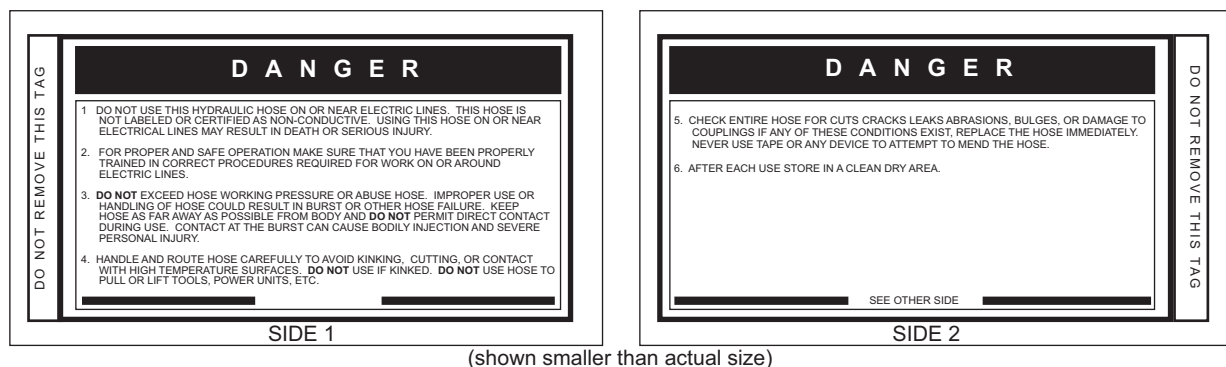

## HOSE PRESSURE RATING

The rated working pressure of the hydraulic hose **must be equal to or higher than** the relief valve setting on the hydraulic system.

# HTMA REQUIREMENTS

## TOOL CATEGORY



## HYDRAULIC SYSTEM REQUIREMENTS

**TYPE I**

**TYPE II**

**TYPE III**

**TYPE RR**

FLOW RATE	4-6 gpm (15-23 lpm)	7-9 gpm (26-34 lpm)	11-13 gpm (42-49 lpm)	9-10.5 gpm (34-40 lpm)
TOOL OPERATING PRESSURE (at the power supply outlet)	2000 psi (138 bar)	2000 psi (138 bar)	2000 psi (138 bar)	2000 psi (138 bar)
SYSTEM RELIEF VALVE SETTING (at the power supply outlet)	2100-2250 psi (145-155 bar)	2100-2250 psi (145-155 bar)	2100-2250 psi (145-155 bar)	2200-2300 psi (152-159 bar)
MAXIMUM BACK PRESSURE (at tool end of the return hose)	250 psi (17 bar)	250 psi (17 bar)	250 psi (17 bar)	250 psi (17 bar)
Measured at a max. fluid viscosity of: (at min. operating temperature)	400 ssu* (82 centistokes)	400 ssu* (82 centistokes)	400 ssu* (82 centistokes)	400 ssu* (82 centistokes)
TEMPERATURE Sufficient heat rejection capacity to limit max. fluid temperature to: (at max. expected ambient temperature)	140° F (60° C)	140° F (60° C)	140° F (60° C)	140° F (60° C)
Min. cooling capacity at a temperature difference of between ambient and fluid temps	3 hp (2.24 kW) 40° F (22° C)	5 hp (3.73 kW) 40° F (22° C)	7 hp (4.47 kW) 40° F (22° C)	6 hp (5.22 kW) 40° F (22° C)
<b>NOTE:</b> Do not operate the tool at oil temperatures above 140° F (60° C). Operation at higher temperatures can cause operator discomfort at the tool.				
FILTER Min. full-flow filtration Sized for flow of at least: (For cold temp. startup and max. dirt-holding capacity)	25 microns 30 gpm (114 lpm)	25 microns 30 gpm (114 lpm)	25 microns 30 gpm (114 lpm)	25 microns 30 gpm (114 lpm)
HYDRAULIC FLUID Petroleum based (premium grade, anti-wear, non-conductive) VISCOSITY (at min. and max. operating temps)	100-400 ssu*	100-400 ssu* (20-82 centistokes)	100-400 ssu*	100-400 ssu*
<b>NOTE:</b> When choosing hydraulic fluid, the expected oil temperature extremes that will be experienced in service determine the most suitable temperature viscosity characteristics. Hydraulic fluids with a viscosity index over 140 will meet the requirements over a wide range of operating temperatures.				

\*SSU = Saybolt Seconds Universal

### NOTE:

These are general hydraulic system requirements. See tool Specification page for tool specific requirements.

---

# OPERATION

---

## PREOPERATION PROCEDURES

---

### CHECK POWER SOURCE

1. Using a calibrated flow meter and pressure gauge, make sure the hydraulic power source develops a flow of 7-9 gpm/26-34 lpm at 1500-2000 psi/105-140 bar.
2. Make certain that the power source is equipped with a relief valve set to open at 2150-2250 psi/150-155 bar maximum.
3. Make certain that the power source return pressure does not exceed 250 psi/17 bar.
4. Make sure the trash pump inlet is clear of debris. Remove any obstruction before operating.

### CONNECT HOSES

1. Wipe all hose couplers with a clean lint free cloth before making connections.

#### **IMPORTANT**

Do not connect pressure to the return port. Motor shaft seal limit is 250 psi/17 bar.

2. Connect the hoses from the hydraulic power source to the couplers on the trash pump or trash pump hoses. It is a good practice to connect return hose first and disconnect it last to minimize or avoid trapped pressure within the trash pump motor.

#### **Note:**

**If uncoupled hoses are left in the sun, pressure increase inside the hoses might make them difficult to connect. Whenever possible, connect the free ends of the hoses together.**

3. Observe the arrow on the couplers to ensure that the flow is in the proper direction. The female coupler on the trash pump is the inlet (pressure) coupler.

## PUMP OPERATION

---

1. Observe all safety precautions.
2. Attach a 3-inch/76 mm diameter hose to the pump outlet. For best performance, keep the discharge hose as short as possible and lay it out to avoid sharp bends or kinks.

Do not attach a nozzle to the outlet end of the discharge hose. For high-pressure water pumping, use a Stanley SM20 or SM50 and nozzle. The TP03 is designed for high GPM water flow at low water pressure (head).

3. Attach a rope or cable to the trash pump's handle. Lower the trash pump into the liquid to be pumped. Do not raise or lower the trash pump by its hoses or couplers to avoid damage to the hoses or couplers.

#### **IMPORTANT**

Never point the hose at bystanders.

4. Turn on the hydraulic power source. Watch for solids in the liquid being pumped. If solids are excessive, the discharge flow might decrease. If this happens, stop the pump and check for the cause of the problem.

Under some conditions, the liquid being pumped might be slowed enough so it can no longer push particles in the liquid. If this happens, particles can accumulate in the pumping chamber, causing further restriction. The impeller then acts as a "grinding wheel" which causes accelerated trash pump wear. Reduced liquid flow can be caused by the following:

- The trash pump sinks into solids at the bottom of the hole.
- The end of the outlet hose is too high, causing an excessive lift height for the column of liquid being pushed by the trash pump. This slows the flow of liquid to a level where it can no longer carry solids.
- The flow and pressure of hydraulic fluid to the trash pump is too low, which reduces impeller speed. A 20 percent decrease in hydraulic fluid flow can reduce pump performance by 50 percent. When operating at reduced hydraulic flow and pressure, the end of the outlet hose should not be more than 30 ft/9 m above the liquid.

#### **Note:**

**It will not damage the pump to operate it "dry."**

---

# OPERATION

---

5. When pumping is complete, set the hydraulic control valve to the "OFF" position. Lift the trash pump from the work area using the rope or cable to avoid damage to the hoses or couplers.

## **IMPORTANT**

Observe the following for trash pump protection and care.

6. The trash pump must maintain a minimum impeller speed in order to move solid particles through the pump. While pumping liquids containing large solids, monitor the flow from the outlet of the fire hose. If it begins to slow, turn off the hydraulic power source and lift the trash pump from the work area. Disconnect the hydraulic hoses and clean at the water hose and the pumping chamber.

## **IMPORTANT**

Pumping liquids with a solids-to liquid ratio greater than 30 percent solids to 70 percent liquid will cause accelerated impeller wear.

7. To maintain optimum performance, it is good practice to periodically inspect the impeller for wear or damage. This is especially important following the pumping of liquids containing sharp, abrasive solids.

---

## **COLD WEATHER OPERATION**

---

If the trash pump is to be used during cold weather, preheat the hydraulic fluid at low power source speed. When using the normally recommended fluids, fluid should be at or above 50°F/10° C (400 ssu/82 centistokes) before use. Damage to the hydraulic system or pump motor seals can result from use with fluid that is too viscous or thick.

---

# EQUIPMENT PROTECTION & CARE

---

## NOTICE

In addition to the Safety Precautions in this manual, observe the following for equipment protection and care.

- Make sure all couplers are wiped clean before connection.
- The hydraulic circuit control valve must be in the “OFF” position when coupling or uncoupling hydraulic tools. Failure to do so may result in damage to the quick couplers and cause overheating of the hydraulic system.
- Always store the tool in a clean dry space, safe from damage or pilferage.
- Make sure the circuit PRESSURE hose (with male quick disconnect) is connected to the “IN” port. The circuit RETURN hose (with female quick disconnect) is connected to the opposite port. Do not reverse circuit flow. This can cause damage to internal seals.
- Always replace hoses, couplings and other parts with replacement parts recommended by Stanley Hydraulic Tools. Supply hoses must have a minimum working pressure rating of 2500 psi/172 bar.
- Do not exceed the rated flow or pressure (refer to Specifications in this manual for correct flow rate and pressure). If specifications are exceeded, rapid failure of the internal seals may result.
- Always keep critical tool markings, such as warning stickers and tags legible.
- Tool repair should be performed by experienced personnel only.
- Make certain that the recommended relief valves are installed in the pressure side of the system.
- Do not use the tool for applications for which it was not intended.

# TROUBLESHOOTING

If symptoms of poor performance develop, the following chart can be used as a guide to correct the problem.

When diagnosing faults in operation of the tool, always make sure the hydraulic power source is supplying the correct hydraulic flow and pressure as listed in the table. Use a flowmeter know to be accurate. Check the flow with the hydraulic fluid temperature at least 80° F/27° C.

PROBLEM	CAUSE	SOLUTION
Pump will not start.	No hydraulic fluid flow or pressure.	Turn on power unit and check that 7-9 gpm/26-34 lpm at 1500-2000 psi/105-140 bar is available at the trash pump.
	Defective couplers.	Check the couplers by connecting them together with the hydraulic power supply operating and with the control valve in the "ON" position. The power supply should operate without "loading" from the couplers.
	Impeller jammed with debris.	Clean the pumping chamber.
	Impeller rubbing against wear plates.	Check and adjust the impeller clearance.
	Defective power module.	Repair or replace the power module.
Poor pump performance.	Hydraulic flow reversed.	Check that the hoses are correctly connected to the pump motor ports. The female coupler should be connected to the "IN" port. The return fluid must never flow through a reversing valve.
	Improper hydraulic fluid flow.	Check that 7-9 gpm/26-34 lpm at 1500-2000 psi/105-140 bar is available at the trash pump. A 20% decrease in flow can result in a 50% decrease in pump performance. 8 gpm/30 lpm is the best circuit flow.
	Trash pump submersed in sediment.	Lift the pump from the bottom of the hole or chamber. Use a flat support under the pump if necessary.
	Trash pump inlet restricted.	Remove restriction and thoroughly clean.
	Discharge hose kinked or restricted.	Straighten the hoses. If the hose must bend at the top of the hole, use a piece of split rigid conduit with large diameter of the expanded hose. This keeps the hose from kinking. Use a 90° 3-inch pipe elbow on the trash pump outlet if necessary.
	Discharge hose too small.	Use a 3-inch diameter hose.
	Water lift too high.	Lower the outlet end of the discharge hose.
	Impeller worn or damaged.	Check impeller for damage and excessive wear. Replace if necessary.
Wear plates worn or damaged.	Check wear plates for damage and excessive wear. Replace if necessary.	
Hydraulic fluid in discharge flow.	Motor shaft seal failure.	Replace the motor shaft seal.  Ensure power unit is delivering 7-9 gpm/26-34 lpm

---

# SPECIFICATIONS

---

Capacity .....	450 gpm/1688 lpm
Weight .....	31 lbs/14 kg
Height (over handle) .....	16.5 in./42 cm
Length .....	14 in./35.5 cm
Width .....	16 in./41 cm
Pressure .....	1500-2000 psi/105-140 bar
Flow Range .....	7-9 gpm/26-34 lpm
Maximum Flow .....	9 gpm/34 lpm
Porting .....	1/2 in. NPTF
Connect Size and Type .....	1/2 in. Male Pipe
Discharge Diameter .....	3 in./76.2 mm Camlock
Inlet Diameter .....	3 in./76.2 mm
System Type .....	OC, HTMA Type II
HTMA Class II .....	7-9 gpm @ 2000 psi
EHTMA Category .....	30 lpm @ 138 bar
Sound Pressure .....	<85 dBA @ 1m
Vibration Level .....	N/A

---

# ACCESSORIES

---

Description	Part No.
Adapter, 3 in. NPT/3 in. Camlock Male .....	52720
Lay-Flat Discharge Hose, 3 in. x 25 ft with Camlock Fittings .....	56761

# TP03 PARTS ILLUSTRATION

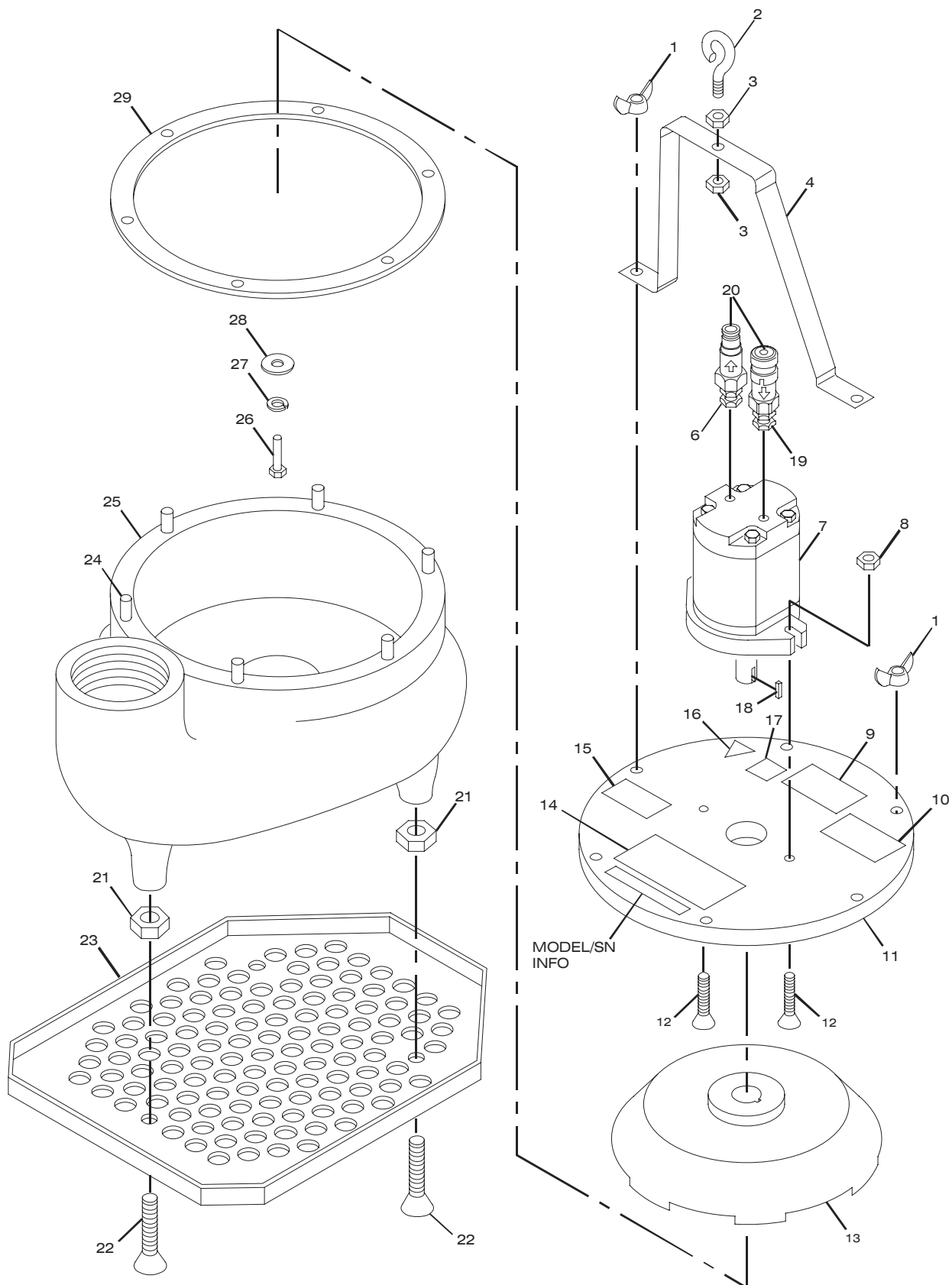



# TP03 PARTS LIST

Item No.	Part No.	Qty	Description
1	07210	6	Wing Nut
2	07208	1	Eye Bolt
3	371503	2	Nut
4	07207	1	Handle
5	----	--	No Item
6	06264	1	Adapter Fitting
7	24381	1	Motor
8	04353	2	Nut
9	03786	1	GPM Decal
10	28322	1	CE Decal (CE Only)
11	07202	1	Motor Adapter Plate
12	21978	2	Capscrew
13	07200	1	Impeller
14	05152	1	Stanley Decal
15	28786	1	Coupler Decal
16	11207	1	Circuit Type D Decal (CE Only)
17	28788	1	Manual Decal (CE Only)
18	00635	1	Key, Motor Shaft
19	39426	1	Adapter
20	03974	1	Coupler Set, 1/2 inch
21	28702	3	Jam Nut
22	38701	3	Screw, Slot FHMS
23	07206	1	Pump Support
24	07209	6	Stud
25	21917	1	Urethane Bowl
	51301		TP0300303 (TP0300301 Army Only)
26	09661	1	Capscrew
27	01324	1	Lockwasher
28	22294	1	Washer
29	07201	1	Rubber Gasket
	<b>26230</b>	<b>1</b>	<b>SEAL KIT</b>

All of these different brands of motors that they used with their ptnb. 24381 – Hydraulic motor (TP03) had the same part number but were made by different manufacturers and have different seal kits. The manufacturer name is usually on the motor.

1. 1st generation = Dowty motor
2. 2nd generation = Hema motor
3. 3rd generation = Cassappa motor
4. 4<sup>th</sup> and current generation = Jihostoj motor

---

# WARRANTY

---

Stanley Hydraulic Tools (hereinafter called "Stanley"), subject to the exceptions contained below, warrants new hydraulic tools for a period of one year from the date of sale to the first retail purchaser, or for a period of 2 years from the shipping date from Stanley, whichever period expires first, to be free of defects in material and/or workmanship at the time of delivery, and will, at its option, repair or replace any tool or part of a tool, or new part, which is found upon examination by a Stanley authorized service outlet or by Stanley's factory in Milwaukie, Oregon to be DEFECTIVE IN MATERIAL AND/OR WORKMANSHIP.

## EXCEPTIONS FROM WARRANTY

**NEW PARTS:** New parts which are obtained individually are warranted, subject to the exceptions herein, to be free of defects in material and/or workmanship at the time of delivery and for a period of 6 months after the date of first usage. Seals and diaphragms are warranted to be free of defects in material and/or workmanship at the time of delivery and for a period of 6 months after the date of first usage or 2 years after the date of delivery, whichever period expires first. Warranty for new parts is limited to replacement of defective parts only. Labor is not covered.

**FREIGHT COSTS:** Freight costs to return parts to Stanley, if requested by Stanley for the purpose of evaluating a warranty claim for warranty credit, are covered under this policy if the claimed part or parts are approved for warranty credit. Freight costs for any part or parts which are not approved for warranty credit will be the responsibility of the individual.

**SEALS & DIAPHRAGMS:** Seals and diaphragms installed in new tools are warranted to be free of defects in material and/or workmanship for a period of 6 months after the date of first usage, or for a period of 2 years from the shipping date from Stanley, whichever period expires first.

**CUTTING ACCESSORIES:** Cutting accessories such as breaker tool bits are warranted to be free of defects in material and or workmanship at the time of delivery only.

**ITEMS PRODUCED BY OTHER MANUFACTURERS:** Components which are not manufactured by Stanley and are warranted by their respective manufacturers.

- a. Costs incurred to remove a Stanley manufactured component in order to service an item manufactured by other manufacturers.

**ALTERATIONS & MODIFICATIONS:** Alterations or modifications to any tool or part. All obligations under this warranty shall be terminated if the new tool or part is altered or modified in any way.

**NORMAL WEAR:** any failure or performance deficiency attributable to normal wear and tear such as tool bushings, retaining pins, wear plates, bumpers, retaining rings and plugs, rubber bushings, recoil springs, etc.

**INCIDENTAL/CONSEQUENTIAL DAMAGES:** To the fullest extent permitted by applicable law, in no event will STANLEY be liable for any incidental, consequential or special damages and/or expenses.

**FREIGHT DAMAGE:** Damage caused by improper storage or freight handling.

**LOSS TIME:** Loss of operating time to the user while the tool(s) is out of service.

**IMPROPER OPERATION:** Any failure or performance deficiency attributable to a failure to follow the guidelines and/or procedures as outlined in the tool's operation and maintenance manual.

**MAINTENANCE:** Any failure or performance deficiency attributable to not maintaining the tool(s) in good operating condition as outlined in the Operation and Maintenance Manual.

**HYDRAULIC PRESSURE & FLOW, HEAT, TYPE OF FLUID:** Any failure or performance deficiency attributable to excess hydraulic pressure, excess hydraulic back-pressure, excess hydraulic flow, excessive heat, or incorrect hydraulic fluid.

**REPAIRS OR ALTERATIONS:** Any failure or performance deficiency attributable to repairs by anyone which in Stanley's sole judgement caused or contributed to the failure or deficiency.

**MIS-APPLICATION:** Any failure or performance deficiency attributable to mis-application. "Mis-application" is defined as usage of products for which they were not originally intended or usage of products in such a manner which exposes them to abuse or accident, without first obtaining the written consent of Stanley. PERMISSION TO APPLY ANY PRODUCT FOR WHICH IT WAS NOT ORIGINALLY INTENDED CAN ONLY BE OBTAINED FROM STANLEY ENGINEERING.

**WARRANTY REGISTRATION:** STANLEY ASSUMES NO LIABILITY FOR WARRANTY CLAIMS SUBMITTED FOR WHICH NO TOOL REGISTRATION IS ON RECORD. In the event a warranty claim is submitted and no tool registration is on record, no warranty credit will be issued without first receiving documentation which proves the sale of the tool or the tools' first date of usage. The term "DOCUMENTATION" as used in this paragraph is defined as a bill of sale, or letter of intent from the first retail customer. A WARRANTY REGISTRATION FORM THAT IS NOT ALSO ON RECORD WITH STANLEY WILL NOT BE ACCEPTED AS "DOCUMENTATION".

## NO ADDITIONAL WARRANTIES OR REPRESENTATIONS

This limited warranty and the obligation of Stanley thereunder is in lieu of all other warranties, expressed or implied including merchantability or fitness for a particular purpose except for that provided herein. There is no other warranty. This warranty gives the purchaser specific legal rights and other rights may be available which might vary depending upon applicable law.



Stanley Hydraulic Tools  
3810 SE Naef Road  
Milwaukie, Oregon  
503-659-5660 / Fax 503-652-1780  
[www.stanley-hydraulic-tools.com](http://www.stanley-hydraulic-tools.com)

---